



## Application Note 3022

### Automatic Control of an MP7ER/MP7FR with an MX2A/MX4A

#### Table of Contents

<b>1. Scope</b> .....	<b>1</b>
1.1 Purpose .....	1
1.2 Relevant Televac Products .....	1
<b>2. Background</b> .....	<b>1</b>
<b>3. Setting up the MX2A/MX4A Open Collector Set Point 1</b> .....	<b>2</b>
<b>4. Connecting the MX2A/MX4A and MP7ER/MP7FR</b> .....	<b>3</b>
<b>5. Additional Considerations</b> .....	<b>4</b>
<b>6. Contact Us</b> .....	<b>4</b>

## 1. Scope

### 1.1 Purpose

The document explains how the open collector set point of an MX2A or MX4A rough vacuum active gauge can be used to automatically control the turn on/off of an MP7ER or MP7FR cold cathode high vacuum active gauge.

### 1.2 Relevant Televac Products

This document applies to the Televac products listed in Table 1:

Description	Part Number
MX2A	2-8910-1XX
MX4A	2-8930-1XX
MP7ER	2-7950-XXX
MP7FR	2-7970-XXX
MX2A/MX4A 6 Conductor Cable	2-9857-XXX
MP7ER/MP7FR 9 Conductor Cable	2-9852-XXX

Table 1

## 2. Background

The Televac MX2A and MX4A are thermal conductivity active gauges for rough vacuum measurement ( $1 \times 10^{-3}$  Torr to 1000 Torr) and the Televac MP7ER and MP7FR are cold cathode active gauges for high vacuum measurement ( $1 \times 10^{-11}$ / $1 \times 10^{-8}$  Torr to  $1 \times 10^{-2}$  Torr).

Because of the design of cold cathodes, it's important that they aren't turned on at pressures above  $1 \times 10^{-2}$  Torr. This helps prevent sputtering, as well as oxidation and contamination which occurs when the cold cathode is turned on at higher pressures, and which causes inaccurate readings and damage to the gauge.

Because the cold cathode can't read above  $1 \times 10^{-2}$  Torr, a rough vacuum gauge such as the MX2A or MX4A must be used to switch the cold cathode on/off at  $1 \times 10^{-2}$  Torr.

The MX2A and MX4A both include an open collector set point, which is essentially a switch that can be set to a specific vacuum reading. In this case our set point is set to  $1 \times 10^{-2}$  Torr. This set point switch can be wired directly to the cold cathode turn on/off control pin of the MP7ER or MP7FR, creating a standalone active vacuum gauge system capable of measuring from  $1 \times 10^{-11}$ / $1 \times 10^{-8}$  Torr to 1000 Torr.

### 3. Setting up the MX2A/MX4A Set Point 1 (Open Collector)

The MX2A/MX4A set point 1 open collector has two settings:

1. SP1H (set point 1 high) - the vacuum reading where the set point deactivates
2. SP1L (set point 1 low) - the vacuum reading where the set point activates

We recommend the following settings for SP1H and SP1L when the set point is used to control an MP7ER/MP7FR:

1. SP1H - 0.012 Torr (equivalent to 12 mTorr, 12 microns, and  $1.2 \times 10^{-2}$  Torr)
2. SP1L - 0.010 Torr (equivalent to 10 mTorr, 10 microns, and  $1.0 \times 10^{-2}$  Torr)

Note that these are recommendations, your system may require different settings.

To change the SP1H and SP1L settings, follow these steps:

1. From the measurement screen, press the SEL key twice
2. The screen will then show "Setpoints SP1L .XXX" (where .XXX is the current setting)
3. Press the ENT key, the top center of the screen will then show "ADJ"
4. Use the up and down arrows to adjust the value until it reads ".010"
5. Press the ENT key, the "ADJ" at the top of the screen will then disappear
6. Press the down arrow, the screen will then show "Setpoints SP1H .XXX" (where .XXX is the current setting)
7. Press the ENT key, the top center of the screen will again show "ADJ"
8. Use the up and down arrows to adjust the value until it reads ".012"
9. Press the ENT key, the "ADJ" at the top of the screen will then disappear
10. Press SEL three times to return to the measurement screen (or wait for the timeout)

The SP1H and SP1L settings can also be changed via RS-485 communications using the W2 command. The command to change the SP1H and SP1L settings to the values recommended above is the following (where X is the address of the unit, default is 0, and <cr> is a carriage return which is equivalent to pressing the enter key on your keyboard):

1. \*XW210021202<cr>

#### 4. Connecting the MX2A/MX4A and MP7ER/MP7FR

These instructions assume the use of Televac MX2A/MX4A cables PN 2-9857-XXX and the Televac MP7ER/MP7FR cables PN 2-9852-XXX. Once you've completed the MX2A/MX4A setup described in [Section 3](#), make the connections listed in Table 2. What this setup will do is supply power to both units, ground the source connection of the MX2A/MX4A set point 1, and connect the open drain of the MX2A/MX4A set point 1 to the cold cathode turn on/off control pin of the MP7ER/MP7FR.

When the system is pumped down and reaches  $1.0 \cdot 10^{-2}$  Torr, the MX2A/MX4A set point 1 will switch, connecting the cold cathode turn on/off control pin of the MP7ER/MP7FR to ground and turning it on. Conversely, when the system is vented or leaked up and reaches  $1.2 \cdot 10^{-2}$  Torr, the control pin will be disconnected from ground, turning off the cold cathode.

**Notes:**

1. The wires shown in the diagram don't need to be directly connected to each other; for example they could be wired through a terminal block in an electronics cabinet.
2. Additional connections may be required to your system; for example the analog 0 to 10 V DC output wires may need to be connected to the analog input of your PLC, or the RS-485 wires may need to be connected to your PLC.

MX2A/MX4A	MP7ER/MP7FR	Description
Pin 5 (Green)	Pin 1 (Brown)	Set point 1 connection to cold cathode turn on/off control pin
Pin 12 (Black)	See description	Connect to power supply (-) ground, connect any way desired
Pin 8 (Red)	Pin 4 (Yellow)	Power supply (+) 24 V DC, these can be connected independently
Pin 15 (Black)	Pin 2 (Red)	Power supply (-) ground, these can be connected independently

Table 2

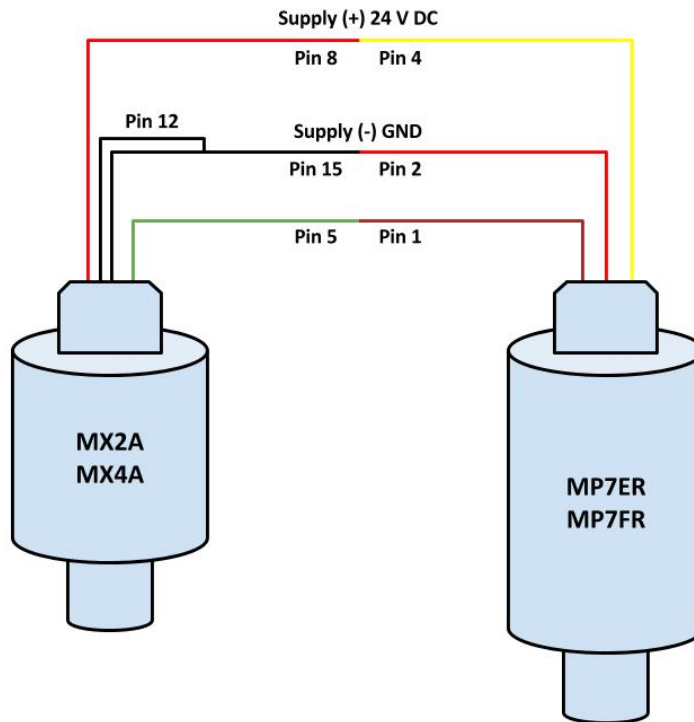

## 5. Additional Considerations

These instructions describe one way that the MX2A/MX4A can be used to automatically switch the cold cathode control pin of an MP7ER/MP7FR. There are various other ways that might be more suited to your unique vacuum system, including the following:

1. Using the MX2A/MX4A set point 2 relay to switch the cold cathode control pin of the MP7ER/MP7FR.
2. Monitoring the analog output of the MX2A/MX4A from a PLC (or other control system), converting the analog output to a vacuum reading, and using the PLC to directly switch the cold cathode control pin of the MP7ER/MP7FR at  $1 \cdot 10^{-2}$  Torr (10 microns).
3. Similar to option 2, but monitoring the MX2A/MX4A vacuum reading using RS-485 communications.

## 6. Contact Us

Please feel free to contact us via email, phone, or on our website live chat:

Televac - The Fredericks Company  
2400 Philmont Avenue  
Huntingdon Valley, PA 19006

Web: [www.frederickscompany.com](http://www.frederickscompany.com)  
Email: [sales@frederickscompany.com](mailto:sales@frederickscompany.com)  
Phone: +1 215 947 2500